



# Raised floors and adjustable pedestals for floorsystems

## CONTENT:

Raised floors MABI .....	2
Raised floor MABI 32 .....	2
Raised floor MABI 18 .....	3
Data sheet MABI 32 + 18.....	3
Deliveries .....	3
Certificates.....	4
Floor assembly .....	4
Adjustable pedestals + matched boards separately.....	5
Adjustable pedestals with noise absorbing underlay for raised floors.....	5
Noise absorbing underlay .....	6
Data sheet .....	6
Deliveries .....	6
Contact.....	7



## Raised floors MABI

### Raised floor MABI 32

This floor is placed on the coarse floor or on bearing ceiling construction. Thanks to these pedestals space between coarse floor and floor MABI develops. The pedestals are protected by an anticorrosive surface finish. The pedestals will be hammered into the pre-drilled holes of the board (1200x600x32mm). Every board is fastened with six pedestals. The insulation compound can be laid over the pedestals on the board. Such assembled board is placed directly on the coarse floor or on the bearing ceiling construction. The matched boards are either dry-rabbeted or by adhesive. The completed assembled floor is usually covered (carpet, linoleum etc.). AL foil must be glued onto the bottom of the antistatic floors. Heat and sonic isolation, interior water and electricity distribution etc. can be installed into the space between the coarse floor and raised floor. Access to installation is possible by way of the revision-cover with opening. The raised floor MABI 32 has been successfully tested in the Testing institute in Prague and has fulfilled all the conditions for the issuing of the certificate.

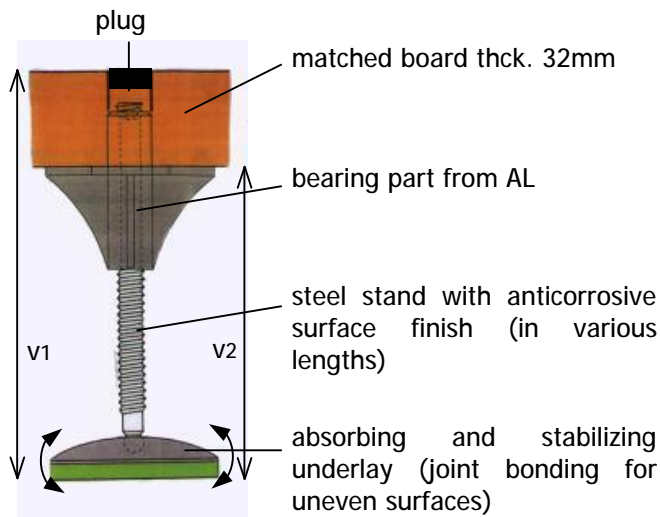

measured with 32 mm board	
total height „v1“	space height „v2“
50 – 75	18 – 43
75 – 115	43 – 83
110 – 150	78 – 118
145 – 185	113 – 153
180 – 220	148 – 188
215 – 255	183 – 223
250 – 290	218 – 258



The completed adjustment of the height of the floor is very easy. The required height can be easily adjusted by screwing. The advantage of these pedestals is permanent flexibility provided by the stabilizing underlay, which significantly mutes noise transfer.

Adjustable floors are suitable for offices, reconstruction of old buildings, hotels, commercial areas, villas, cellars, etc..

#### Main Advantages:

- dry assembly, permanent flexibility, improvement of impact noise protection=33dB
- low weight , easy floor assembly
- adjustability , space utilization (distribution, isolation)
- floor covering can be done 1 day after assembly

## Raised floor MABI 18



This is the same system as MABI 32; the only difference is the 18mm board thickness. These boards are used as the groundwork for anhydrite surface. This system has been successfully tested in the Testing institute in Prague and has fulfilled all the conditions for the issuing of the certificate.

### Data sheet MABI 32 + 18

q particleboard dimension (0,72m <sup>2</sup> )	1 200 x 600 mm
q self-weight MABI 32	22,0kg / m <sup>2</sup>
q space loading allowed ČSN EN 12825	5,0kN / m <sup>2</sup> = 500kg/m <sup>2</sup>
q point loading allowed (range 40cm) ČSN EN 12825	3,0kN = 300kg
q flammability class ÖNORM B 3800 (ČSN 13986)	B 2 (C1)
q emission class EN 312 – 1	E 1
q damp resistance	P5 (V100)
q heat conductivity	0,13 W / m <sup>2</sup> K
q improvement of impact noise protection ČSN EN ISO 140-7 , ČSN EN ISO 717-2	Δ Lw = 33 dB
q floor viability after	30 min.
q floor covering after	1 day
q adjustable pedestals– 6pcs / board (8pcs. / m <sup>2</sup> )	
q plug for pedestals – 6pcs / board (8pcs / m <sup>2</sup> )	
q when placing boards having a length over 10m a kerf must be done	
q when placing boards respect a wall distance of 10mm	
q under specific conditions a light partition wall to 100kg/lm can be built directly onto the matched boards	
q store in dry room	

### Deliveries

M-S Mabo-Systém Group s.r.o provides the deliveries including floor assembly in the Czech Republic .

## Certificates



## Floor assembly

### Before you start:

All unfinished work (windows, installation, plaster, etc.) has to be finished before the floor delivery. The insulation against wetness have to be laid in the wet area before floor assembly.

- Designate the direction of floor laying.
- You must cut off the feather of the end boards.
- Respect a min. wall distance of 10mm.
- Glue the one-sided adhesive margin strip onto the wall before the floor laying.
- Respect the total height of the floor.



Check the total height of the floor and hammer suitable pedestals into the pre-drilled holes of the board (6 pcs/board). Different pedestals for the board can be used with uneven surfaces.

- After all pedestals have been hammered, lay the heat insulation 1200 x 600mm onto the same board.
- If the entire floor is fully insulated, it will provide optimal heat insulation.





Now hammer the noise absorbing underlay onto the hinge(joint) of the pedestal.

The first board must be laid into the corner in such a way that the margin strip will not be pressed. Respect the total height of floor while measuring. The wall distance of the last pedestal can't be more than 13cm. The last board can't be smaller than 20cm. Firstly adjust the four edge pedestals and then both middle ones. When adjusting don't unscrew too much up and when levelling don't load the board. When placing boards having a length over 10m a kerf must be done

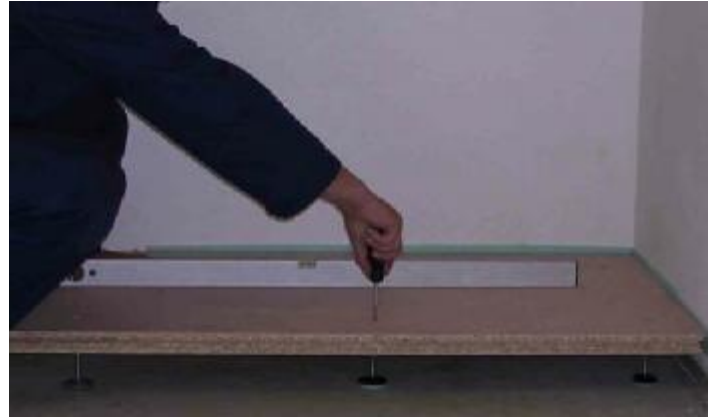

The matched boards are either dry-rabbeted or can be coated with wood adhesive for better connection. Respect that the floor should not be walked on for 30minutes to allow for the glue to dry. It is necessary to manually pre-drill the holes into cut-up boards at the end of assembly. The boards must be completely laid together. The surface temperature of warm water distribution pipes can't exceed the room temperature by more than 5°C. The distribution of cold water must be done in such a way to prevent condensation.

The plugs will be hammered the day after floor assembly. Check the plane of the floor before you hammer the plugs.



## Adjustable pedestals + matched boards separately

### Adjustable pedestals with noise absorbing underlay for raised floors



type	hollow height V2(mm)
S1	18 – 43
S2	43 – 83
S3	78 – 118
S4	113 – 153
S5	148 – 188
S6	183 – 223
S7	218 – 258

The pedestals are used to acquire space between coarse floor(basicfloor) and raised floor. This system is specified for particleboards(matched boards) with a slip feather (match joint) and raised floors with an anhydrite surface. More in section „**Raised floors MABI**“.

These pedestals can be used for height alignment of floor joist (for example) and isolation is placed between. The end floor is placed directly on this floor joist, which means the matched boards are not needed. The pedestals are also suitable for other height alignments, where flexibility and height adjustment is needed. The hinge of the pedestal is suitable for uneven surfaces.

### Noise absorbing underlay



Noise absorbing underlay is made of flexible material. It is specified for high loads to withstand wet surfaces. The size and form are to be adapted to the customer needs. The recommended size is 50 – 100mm. The thickness is between 3 – 5mm. This underlay is suitable for the pedestals of other producers.

Underlay form : ● ■ ■■

### Data sheet

#### Pedestal:

- q bearing part(head)
- q steel stand with thread
- q anticorrosive surface

ALSi12Cu1  
free-cutting steel 11SMn28k  
galvanized

#### Underlay:

- q covering
- q underlay
- q bearing capacity

PA6  
Elastorn G  
3KN

### Deliveries

Deliveries can be as follows:

- ü pedestals only (matched boards + floor assembly provided by customer)
- ü pedestals with matched boards (floor assembly provided by customer)
- ü underlays only (for pedestals of other producers)
- ü complete floor assembly of MABI 32 or MABI 18 (Czech market only)-more info see „Raised floors MABI“

## Contact

Producer	Assembly
 <p><b>direct contact:</b> Petr Bíško Tel: 00420-376/316 702 Fax: 00420-376/316 702 <a href="mailto:petr.bisko@vjbpartner.cz">petr.bisko@vjbpartner.cz</a></p>	<p><b>m - S Mabo – systém Group s.r.o</b></p> <p><b>Firm location:</b> M-S Mabo-systém Group s.r.o Teplárenská 25 CZ 36004 Karlovy Vary pan Ivan Málek Tel: 00420-353/227 900 , 920 Fax: 00420-353/227 910 email: <a href="mailto:mabosystem@volny.cz">mabosystem@volny.cz</a></p>